

SO-1064-10534

ENGINEERING DATA SHEET

RELAY SOCKET
10 AMP



BASIC SOCKET SERIES DESIGNATION FOR:

Series XCL

DESIGNED TO THE STANDARDS AND REQUIREMENTS OF:

MIL-S-12883

SOCKET DRAWING

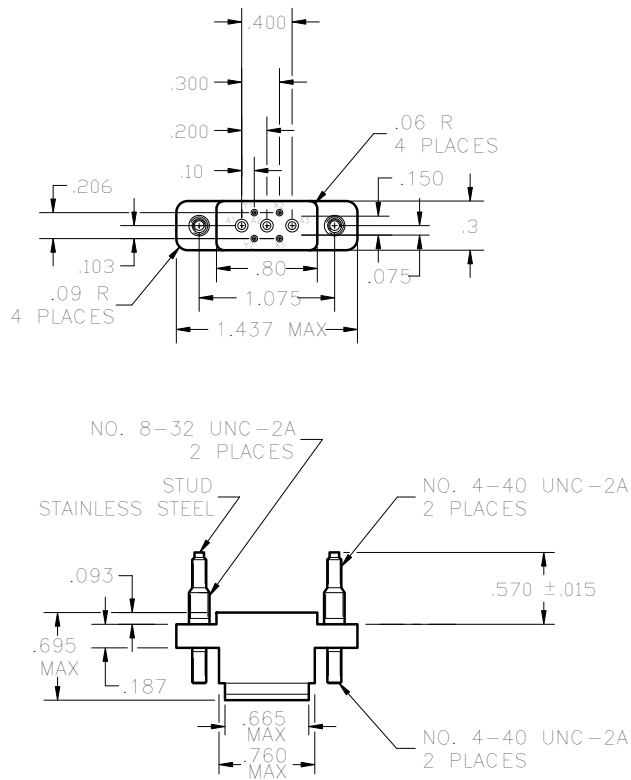

HARDWARE MOUNTING

MOUNTING DETAIL 2 PLACES

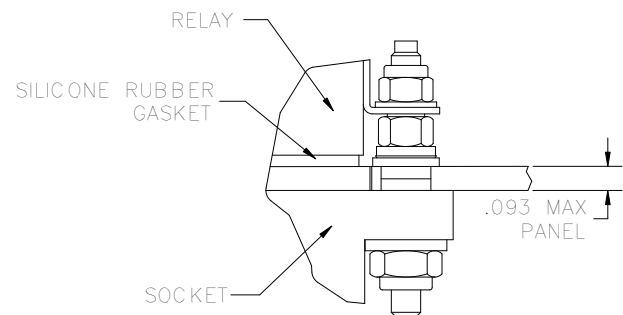

BOTTOM MOUNT-CLEARANCE
HOLE FOR .164 SCREW
TOP MOUNT-CLEARANCE
HOLE FOR .112 SCREW

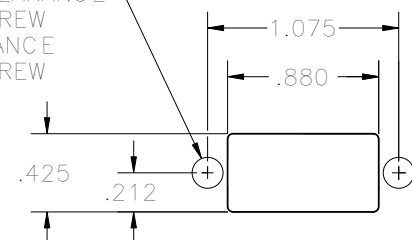

MOUNTING DIMENSIONS

GENERAL CHARACTERISTICS

1. Supplied with mounting hardware No. 16 contacts, No. 16 crimp for power terminals; No. 20 contacts, No. 20 crimp for coil terminals.

2. Standard tolerances

.xx ±.01; xxx ±.005.

3. Weight

.036 lb. max

4. Temperature range

-70° C to +125° C



Leach International
www.leachintl.com

North America
6900 Orangethorpe Ave.
P.O. Box 5032
Buena Park, CA 90622 USA

Tel: (01) 714-736-7599
Fax: (01) 714-670-1145

Europe, SA
2 Rue Goethe
57430 Sarralbe
France

Tel: (33) 3 87 97 98 97
Fax: (33) 3 87 97 84 04

Asia-Pacific Ltd.
20/F Shing Hing Commercial Bldg.
21-27 Wing Kut Street
Central, Hong Kong

Tel: (852) 2 191 2886
Fax: (852) 2 389 5803

Data sheets are for initial product selection and comparison. Contact Leach International prior to choosing a component.