

LIMIT SWITCHES

Series - HH

Hermetically Sealed Switches

FEATURES & SPECIFICATIONS

OPTIONS

CURRENT RATINGS

- Meets MILS-8805 Enclosure Design 5 (Hermetic)
- Mechanical life: 25,000 cycles
- Electrical life: 25,000 cycles
- Operating temperature: -65°F to +185°F (-55°C to +85°C)
- Leak rate less than 1×10^{-8}
- Rugged stainless steel construction
- Inert gas filled

- Low level circuitry capability
- Rear or side exit connector
- RFI/EMI shielded cable
- High temperature operation
- Ball bearing plunger
- Custom bushing and plunger sizes
- Roller plunger available in 45° increments
- Special purpose designs

	Amperes - 28VDC		
	Resistive	Inductive	Motor
Sea Level	7.0	4.0	4.0
50,000 feet	7.0	2.5	4.0
Low Level Rating	0.1	0.1	—

HERMETICALLY SEALED LIMIT SWITCHES



TWO POLE MINIATURE

P/N	DESCRIPTION
HH-630A	Plunger Side Exit
HH-630B	Plunger Rear Exit
HH-631A	Roller Side Exit
HH-631B	Roller Rear Exit

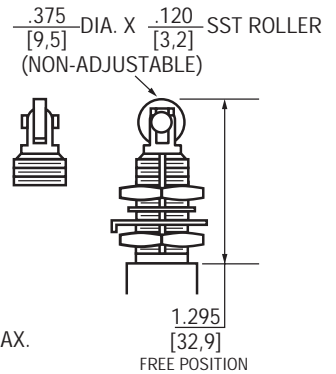
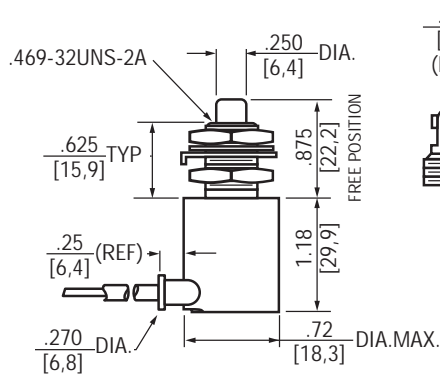
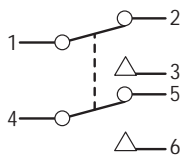

FOUR POLE SERIES

P/N	DESCRIPTION
HH-695A	Plunger Side Exit
HH-695B	Plunger Rear Exit
HH-696A	Roller Side Exit
HH-696B	Roller Rear Exit

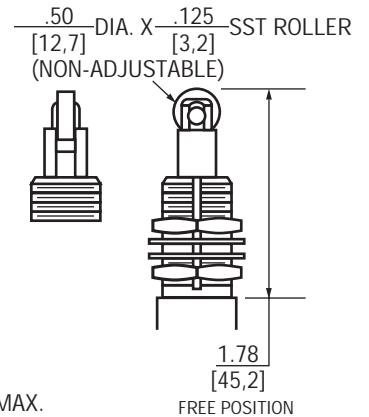
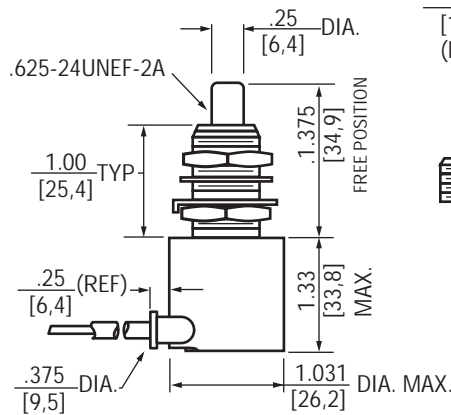
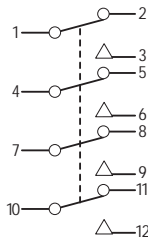

TYPICAL CONSTRUCTION - REAR EXIT DESIGN

HARDWARE SUPPLIED
UNASSEMBLED

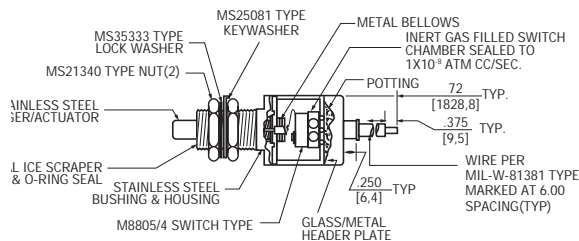

STANDARD

0.00 = inches

[0,0] = mm

Dimensions for reference only.