

PUSHBUTTON SWITCHES

Series - 8870, 8809

Special Designed Pushbutton Switches

FEATURES	SPECIFICATIONS	CURRENT RATINGS						
		Catalog Number	28VDC			115VAC 60 or 400Hz		
<ul style="list-style-type: none"> All switches employ momentary action Foot or hand operation designs Plunger has ice and mud scraper Mechanical lock on 8909K559 Mechanical lock has spring loaded release design Logic to power switching load capability 	<ul style="list-style-type: none"> MS approved and QPL'd to MIL-S-8805 Temperature Range: -40°F to +185°F (-40°C to +85°C) Life: 20,000 operations at rated load 50,000 operations mechanical life 			Resistive Load	Inductive Load	Lamp Load	Resistive Load	Inductive Load
		8870K2	25	10	4	15	7.5	2
		8870K3	25	10	4	15	7.5	2
		8870K4	25	10	4	15	7.5	2
		8870K5	25	10	4	15	7.5	2
		8909K559	6	—	—	6	—	—

SELECTION TABLE

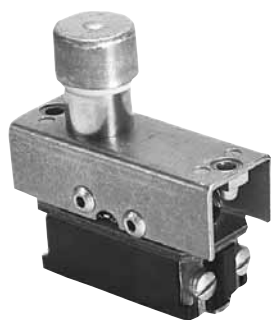

8870K2 & K4



8870K3 & K5



8909K559

Poles and Throw	Circuit Arrangement		Mounting	Features	Government Part Number	Catalog Number
	Normal	Depressed				
1 P.S.T.	OFF	ON*	Flush ^②	Microphone PB Switches Foot Operated	M8805/55-001	8870K2
					M8805/55-002	8870K3
					M8805/55-003	8870K4
					M8805/55-004	8870K5
2 P.S.T.	OFF	ON*	Flush ^②	Roller Operated	—	8909K559 ^①

* Momentary contact.

^① Electrical life of 8909K559 is 12,000 operations.

^② See page B25 for mounting data.

OPTIONS/ACCESSORIES

- Terminal screws furnished assembled
- Double throw contacts - 8870
- Special marking

APPROXIMATE DIMENSIONS - 8870K2, K3, K4, K5

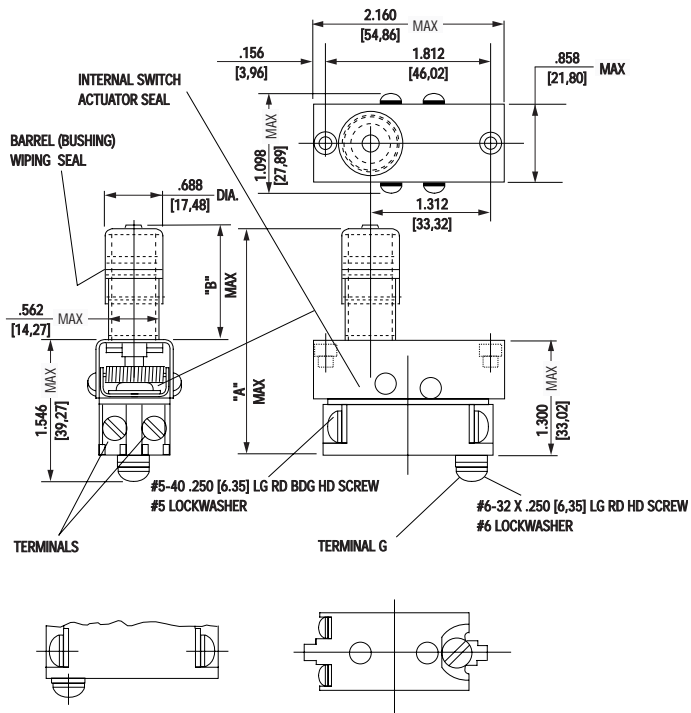

8870K5	2.968	1.660	6-32 UNC-2B
8870K4	2.218	.910	6-32 UNC-2B
8870K3	2.968	1.668	6-40 UNF-2B
8870K2	2.218	.910	6-40 UNF-2B
CAT.NO.	A	B	INSERT & NUT THREAD

APPROXIMATE DIMENSIONS - 8909K559

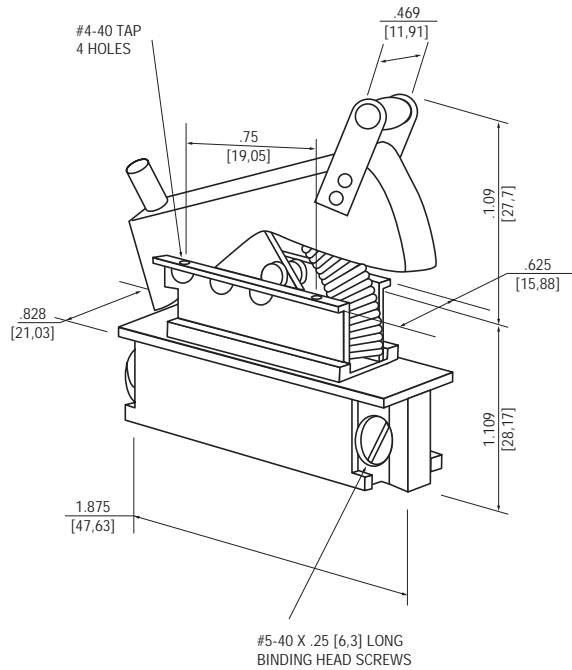

STANDARD

0.00 = inches

[0,0] = mm

Dimensions for reference only.