



Standard

The space-qualified product utilizes the same internal design.

Three-Phase Protection

Qualified

To MS14154 of MIL-C-5809.

Lightweight

Weighs 68 grams maximum (0.15 lbs).

Vibration Resistance

Vibration resistance and mechanical life exceed MIL Specs — including random vibration.

Miniature Size — High Performance

19.8mm, 46.7mm, 35.0mm behind panel depth.

Temperature-Compensated

Ambient-temperature-compensated from -55°C to +71°C. Note: higher operating ranges are available.

Performance Rated Circuit Breaker

This lightweight, miniature, three-phase circuit breaker, Series 4330, reflects the latest advancements in circuit breaker design, incorporating self-wiping contacts, tight tolerances in design, and stringent manufacturing standards. It is fungus-proof and highly resistant to corrosion. The trip-free thermal mechanism avoids nuisance trips (even during temporary surges of starting loads) under ambient temperatures ranging from -55°C to +71°C. Calibration integrity is maintained through wide variations in ambient temperature and altitude, making this circuit breaker ideal for applications where temperature is not controlled.

Multiple Options

This series is available in many optional configurations.

It is presently being manufactured with 7/16, 15/32 and metric mounting sleeves. Many versions of different terminals, barriers, and hardware are current production items. Several different button options provide our customers with additional flexibility.

PERFORMANCE DATA

Interrupting Capacity	1,200A balanced at 205V, 400Hz, AC and 2,000A unbalanced at 120V, 400Hz, AC, at sea level and 70,000 feet
Endurance	120V, 400 Hz., AC: inductive load — 2,500 cycles; resistive load — 5,000 cycles; mechanical cycling no load — 5,000 cycles
Overload Cycling	100 cycles at 200%
Dielectric Strength	At sea level, 25°C 1,500V, AC. At 70,000 ft. +71°C 500V, AC
Insulation Resistance	Not less than 100 megohms at 500V, DC
Voltage Drop	Varies with rating (see "Ordering Information")
Vibration	Meets specification MIL-STD-202, Method 204, Condition A-10G., 10-500 Hz. MS "V" type, meets Condition B, 15G, 10-2,000 Hz. and Condition C 10G, 10-2,000 Hz.
Shock	50G's. MIL-STD-202, Method 213 Test G
Acceleration	Exceeds 10G's
Weight	68 grams max. (0.15 lbs.)

OVERLOAD CALIBRATION DATA

Specification Table	@ 25°C		@ +71°C		@ -55°C		Test Time Parameters
	MIN	MAX	MIN	MAX	MIN	MAX	
Must Hold	110	—	100	—	110	—	% For 1 Hour
Must Trip	—	145	—	145	—	165	% Within 1 Hour
200% Overload	4.00	20.00	3.00	20.00	6.00	40.00	Seconds
500% Overload	0.40	2.00	0.33	1.70	0.55	3.50	Seconds
1000% Overload	0.10	0.53	0.08	0.40	0.15	0.80	Seconds

ORDERING INFORMATION

MS APPROVAL STATUS	AMPERE RATING	VOLTAGE DROP MAX.*	STANDARD		LONG BUTTON		HIGH VIBRATION		LONG BUTTON VIBRATION	
			MS P/N	EATON MP P/N	MS P/N	EATON MP P/N	MS P/N	EATON MP P/N	MS P/N	EATON MP P/N
MS Approved	1	1.10	MS14154-1	4330-001-1	MS14154-1L	4330-007-1	MS14154-1V	4330-008-1	MS14154-1VL	4330-009-1
MS Approved	2	0.75	MS14154-2	4330-001-2	MS14154-2L	4330-007-2	MS14154-2V	4330-008-2	MS14154-2VL	4330-009-2
MS Approved	2 1/2	0.70	MS14154-2 1/2	4330-001-205	MS14154-2 1/2L	4330-007-205	MS14154-2 1/2V	4330-008-205	MS14154-2 1/2VL	4330-009-205
MS Approved	3	0.55	MS14154-3	4330-001-3	MS14154-3L	4330-007-3	MS14154-3V	4330-008-3	MS14154-3VL	4330-009-3
MS Approved	4	0.45	MS14154-4	4330-001-4	MS14154-4L	4330-007-4	MS14154-4V	4330-008-4	MS14154-4VL	4330-009-4
MS Approved	5	0.35	MS14154-5	4330-001-5	MS14154-5L	4330-007-5	MS14154-5V	4330-008-5	MS14154-5VL	4330-009-5
MS Approved	7 1/2	0.30	MS14154-7 1/2	4330-001-705	MS14154-7 1/2L	4330-007-705	MS14154-7 1/2V	4330-008-705	MS14154-7 1/2VL	4330-009-705
MS Approved	10	0.28	MS14154-10	4330-001-10	MS14154-10L	4330-007-10	MS14154-10V	4330-008-10	MS14154-10VL	4330-009-10
MS Approved	15	0.28	MS14154-15	4330-001-15	MS14154-15L	4330-007-15	MS14154-15V	4330-008-15	MS14154-15VL	4330-009-15
MS Approved	20	0.25	MS14154-20	4330-001-20	MS14154-20L	4330-007-20	MS14154-20V	4330-008-20	MS14154-20VL	4330-009-20

* AT RATED NOMINAL CURRENT
For other amperage ratings and configurations, consult the Business Unit.

DIMENSIONS

MIL Spec	Part No.	A*Max.	B*Min.
MS14154	4330-001	0.750	0.470
MS14154L	4330-007	1.125	0.845
MS14154V	4330-008	0.750	0.470
MS14154VL	4330-009	1.125	0.845

Min. Panel Thickness .025
 Max. Panel Thickness .100

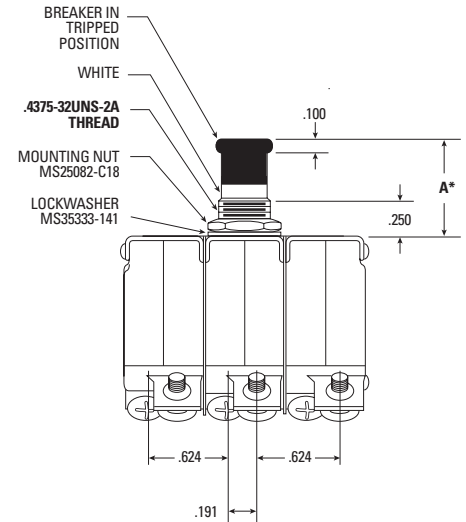
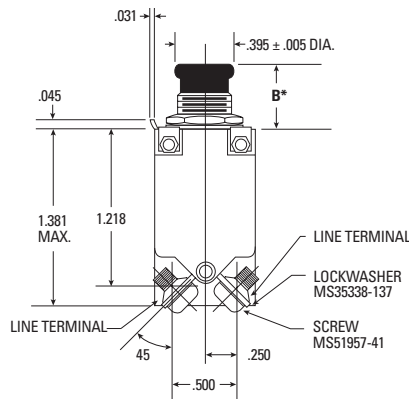
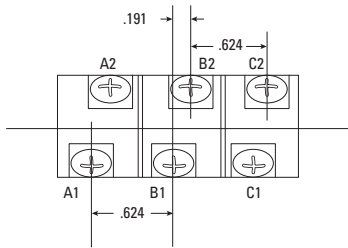
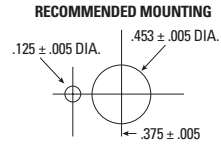
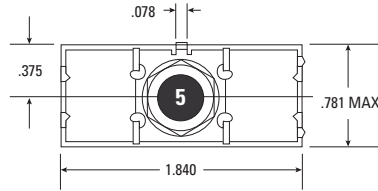

TRIP CURVE

