



**Single-Pole High Performance**

**Protection For Very High Current Rated Circuits**

Protects circuits from 125 to 200 amperes.

**Meets MS Mounting Dimensions**

Has mounting dimensions compatible with Military Standard Drawing requirements of MS25017 of MIL-C-5809.

**Heavy-Duty Components**

Extra heavy contacts and wide sturdy terminals.

**Trouble-Free Contact Life**

Contacts mounted on spring-loaded pivots to maintain high-contact pressure and to improve arc quenching capability.

**Performance Rated Circuit Breaker**

The 170 series is the only compact, reliable, heavy-duty aircraft-type circuit breaker available in the 125 to 200 ampere range. It is the only device in this range that has mounting dimensions compatible with Military Standard Drawing MS25017. Designed to protect heavy-duty aircraft electrical systems, the breaker features separate overload and mechanical latches. The unit's trip-free design prevents it from being held closed manually against any overload that would ordinarily cause it to open. The breaker may be used on either AC or DC circuits.

**PERFORMANCE DATA**

<b>Interrupting Capacity</b>	3,000A at 28V, DC; 2,500A at 115V, AC
<b>Endurance</b>	At 120V, 400 Hz.: inductive load — 2,500 cycles; resistive load — 5,000 cycles; at 30V, DC: inductive load — 1,000 cycles; resistive load — 5,000 cycles; mechanical cycling, no load — 5,000 cycles
<b>Overload Cycling</b>	100 operations at 200% rated current and rated voltage
<b>Dielectric Strength</b>	1,500V, minimum
<b>Insulation Resistance</b>	Not less than 100 megohms at 500V, DC
<b>Voltage Drop</b>	0.1 volt maximum at rated current
<b>Vibration</b>	Exceeds MIL-STD-202, Method 204, Condition A
<b>Shock</b>	Exceeds 30G's, 11 Millisec (half-sine pulse) MIL-STD-202, Method 213 Test J
<b>Acceleration</b>	Exceeds 10G's
<b>Weight</b>	130 grams (0.286 lbs.)

**OVERLOAD CALIBRATION DATA**

Specification Table	@ 25°C		@ +71°C		@ -40°C		Test Time Parameters
	MIN	MAX	MIN	MAX	MIN	MAX	
Must Hold	100	—	70	—	110	—	% For 1 Hour
Must Trip	—	125	—	125	—	160	% Within 1 Hour
200% Overload	15	70	—	—	—	—	Seconds
400% Overload	2	12	—	—	—	—	Seconds
600% Overload	1	5	—	—	—	—	Seconds

Trip curve available.

**ORDERING INFORMATION**

Ampere Rating	Voltage Drop Max.*	Part Number
125	.100	170-001-125
140	.100	170-001-140
150	.100	170-001-150
160	.100	170-001-160
180	.100	170-001-180
200	.100	170-001-200

\* At rated nominal current.

Three phase variants are available as a 970 Series. Also available as a 180 Series device for ratings up to 300 amperes. For other amperage ratings and configurations, consult the Business Unit.

DIMENSIONS

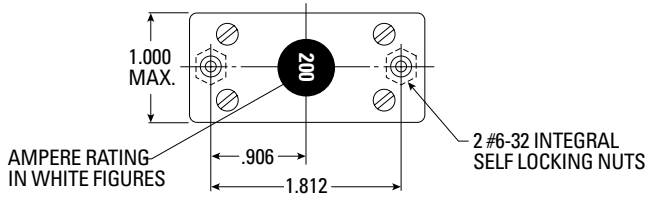

RECOMMENDED MOUNTING

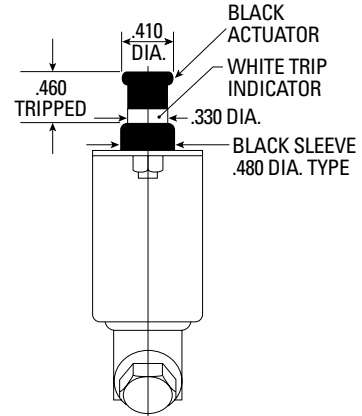
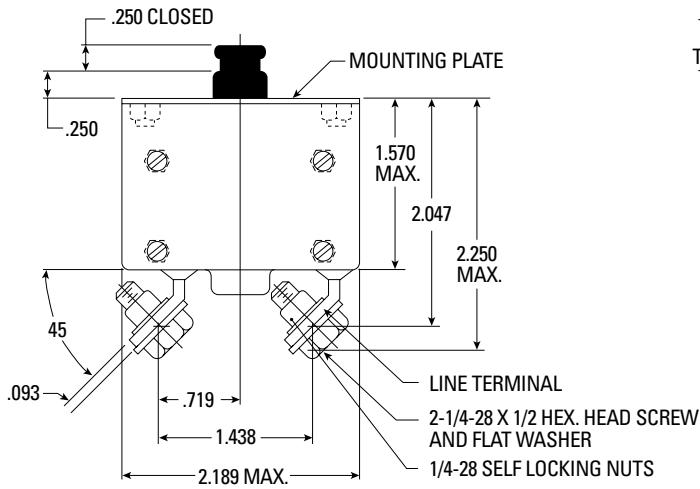
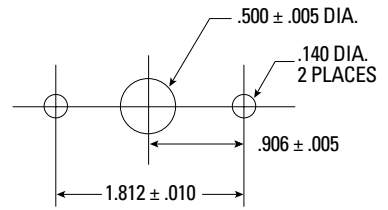

TRIP CURVE

