



Three-Pole High Performance

Three-Phase Protection

Common trip mechanism trips all three phases, regardless of which phase is overloaded.

Integral Barriers

Terminals are separated by barriers molded into the case.

Single-Hole Mounting

For quick, easy installation.

Shock And Vibration Resistant Construction

Permits use in various types of portable and mobile airborne equipment.

Performance Rated Circuit Breaker

The 1536-001 is a lightweight, miniature breaker that features three bimetal sensing elements having very fast electro-dynamic response under short circuit conditions, and standard trip characteristics at lower levels of overloads.

Single hole mounting and small size facilitate easy installation. The breaker's one-piece, glass-filled case features integrally-molded barriers to separate the terminals.

PERFORMANCE DATA

Interrupting Capacity	1,000A at 205V, 400 Hz., three-phase symmetrical fault 1,000A at 120V, 400 Hz., single-phase fault
Endurance	At 120VAC, 400 Hz.: inductive load — 5,000 cycles; resistive load — 5,000 cycles; mechanical cycling, no load — 5,000 cycles
Overload Cycling	100 operations at 200% load
Dielectric Strength	1,500V, minimum
Insulation Resistance	Not less than 100 megohms at 500V, DC
Voltage Drop	Varies with rating (see "Ordering Information")
Vibration	Exceeds MIL-STD-202, Method 204, Condition A
Shock	Exceeds 30G's, 11 Millisec (half-sine pulse) MIL-STD-202, Method 213 Test J
Acceleration	Exceeds 10G's
Weight	181 grams (.40 lbs.)

OVERLOAD CALIBRATION DATA

Specification Table	@ 25°C		@ +71°C		@ -55°C		Test Time Parameters
	MIN	MAX	MIN	MAX	MIN	MAX	
Must Hold	105	—	70	—	130	—	% For 1 Hour
Must Trip	—	138 Balanced*	—	110	—	160	% Within 1 Hour
200% Overload	10.00	70.0	—	—	—	—	Seconds
400% Overload	2.00	10.0	—	—	—	—	Seconds
600% Overload	1.00	4.0	—	—	—	—	Seconds
1000% Overload	0.35	1.4	—	—	—	—	Seconds

* Unbalanced load, individual phases: 145%
Trip curve available.

ORDERING INFORMATION

Ampere Rating	Voltage Drop Max.*	Part Number
5	0.350	1536-001-5
7 1/2	0.325	1536-001-705
10	0.300	1536-001-10
15	0.250	1536-001-15
20	0.200	1536-001-20
25	0.180	1536-001-25
30	0.180	1536-001-30
35	0.175	1536-001-35
40	0.175	1536-001-40
50	0.150	1536-001-50

* At rated nominal current.
For other amperage ratings and configurations, consult the Business Unit.

DIMENSIONS

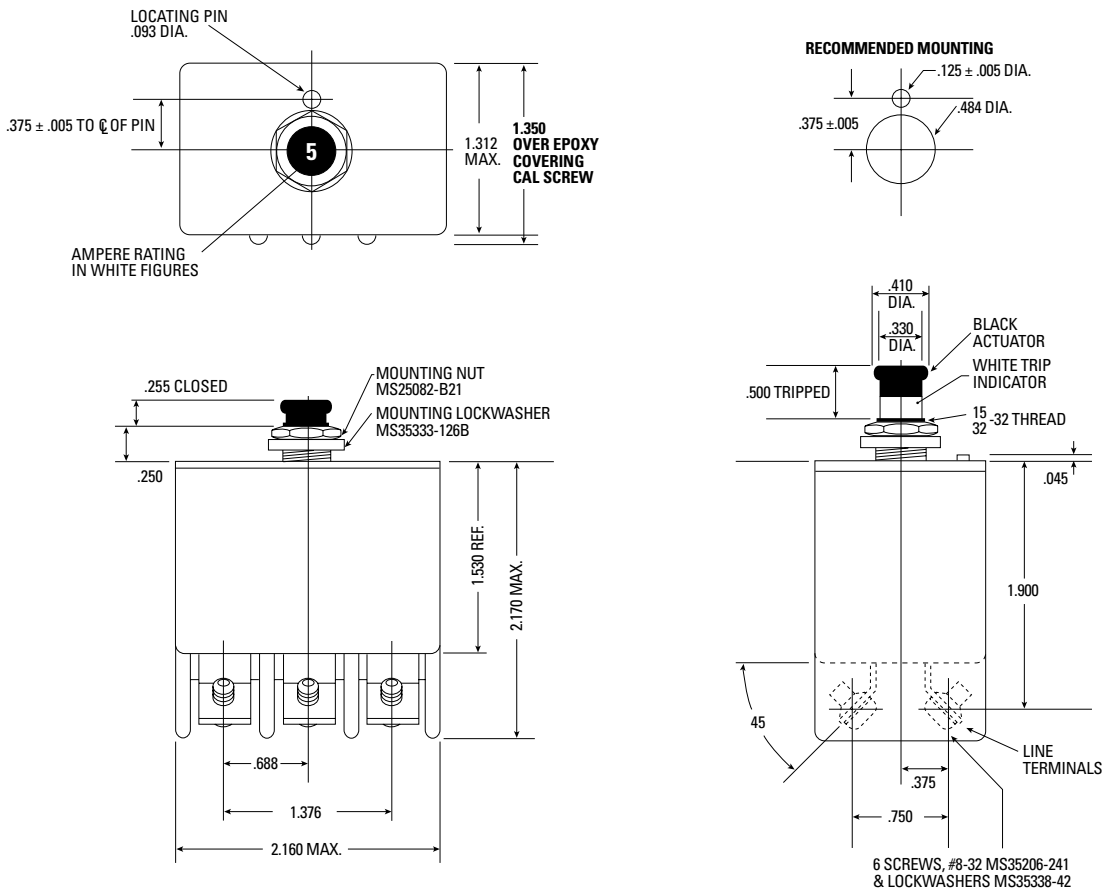

TRIP CURVE

