

## Description

Three pole, miniaturised, aircraft style thermal circuit breaker with tease-free, trip-free, snap action mechanism and push/pull on/off manual actuation (M-type TO CBE to EN 60934). An indicator band on the push button clearly shows the tripped/off position. Threadneck panel mounted, available in metric and US (AS 14154) configurations. Advanced two-chamber design minimises contact contamination to provide fail-safe operation. Temperature compensated with optional auxiliary contacts, and fully approved for use on a wide range of aircraft and equipment. For single pole version see type 483.

## Typical applications

Aircraft systems and equipment (fixed wing and helicopters); other extra low voltage wiring applications; defence equipment; communications systems.

## Standard current ratings and typical volt drop values

Current rating (A)	Volt drop per pole (mV)	Current rating (A)	Volt drop per pole (mV)
1	750	7.5	230
2	520	10	190
2.5	400	15	190
3	360	20	200
4	350	25	170
5	260	30	160

## Approvals

Approvals:

LN 29887

VG 95345, part 11

prEN 2996

AS 14154

QPL



without auxiliary contact

583-...

with auxiliary contact

## Technical data

Voltage rating	3 AC 200 V (400 Hz); DC 28 V	
Current rating range	1...30 A	
Auxiliary circuit	0.5 A, DC 28 V	
Typical life	20,000 operations mechanical 10,000 operations at $I_N$ ( $\leq 25$ A) 4,000 operations at $I_N$ (30 A)	
Ambient temperature	-55...+125 °C (-67...+257 °F) $\leq 15$ A -55...+90 °C (-67...+194 °F) $> 15$ A	
Insulation co-ordination (IEC 60664 and 60664A)	rated impulse withstand voltage 1.5 kV	pollution degree 3
Dielectric strength (IEC 60664 and 60664A)	test voltage operating area pole/pole main to aux. circuit	AC 1,500 V AC 1,500 V AC 1,500 V
Insulation resistance	$> 100$ M $\Omega$ (DC 500 V)	
Interrupting capacity $I_{cn}$	3 AC 200 V (400 Hz): $\leq 4$ A                    1,000 A 5 A                        2,000 A 7.5...25 A               2,500 A 30 A                      1,500 A DC 28 V: 1...25 A                   6,000 A 30 A                      4,000 A	
Degree of protection (IEC 60529/DIN 40050)	operating area IP40 terminal area IP00	
Vibration (sinusoidal)	10 g (57-2000 Hz) $\pm 0.76$ mm (5-57 Hz) to VG 95210, sheet 19/ IEC 60068-2-6, test Fc/ISO 7137	
Vibration (random)	16.4 g rms, 0.2 g <sup>2</sup> Hz $\pm 1.5$ dB, to VG 95210, sheet 29/ IEC 60068-2-6, test Fc/ISO 7137	
Acceleration	17 g, to ISO 2669	
Shock	50 g (11 ms), to VG 95210, sheet 28/ IEC 60068-2-27, test Ea/ISO 7137	
Corrosion	96 hours at 5 % salt mist 48 hours at 20 % salt mist to VG 95210, sheet 2/ IEC 60068-2-11, test Ka/ISO 7137	
Humidity	240 hours at 95 % RH, to VG 95210, sheet 7/ IEC 60068-2-3, test C/ISO 7137	
Explosion	to VG 95210, sheet 10/ MIL-STD-202, meth. 109	
Altitude	$\leq 25,000$ m above sea level	
Mass	max. 67 g with auxiliary contact max. 63 g without auxiliary contact	

**Mass reduction through aluminium threadneck approx. 3 g**

## Ordering information

### Type No.

583 three pole, with temperature compensation

### Mounting

G threadneck panel mounting

### Threadneck design

- 1 M12x1x6.4x8.8 dia. with mounting plate (aux. contact version)
- 2 15/32-32UNx6.4x7.8 dia. (only without aux. contact)
- 3 MJ12x1x6.4x8.8 dia. (only without aux. contact)
- 4 M12x1x6.4x8.8 dia. (only without aux. contact)
- 5 7/16-32UNx6.4x7.8 (only without aux. contact)
- 6 M12x1x9.4x8.8 dia. (without aux. contact)
- 7 7/16-32 UNx6.4x7.8 dia. with mounting plate (aux.contact version)
- 8 M12x1x6.4x8.8 with mounting plate, aluminium threadneck
- 9 M12x1x6.4x8.8, aluminium threadneck

### Hardware for threadneck (washers)

- 0 without hardware
- 1 corrugated washer 12/15, fitted
- 2 serrated lock washer 12.1/17.2, fitted
- 3 serrated lock washer 11.3/14.9, fitted
- 4 serrated lock washer 12/15, fitted

### Hardware for threadneck (nuts)

- 0 without hardware
- 1 hex nut M12x1
- 2 hex nut 15/32-32UN
- 3 hex nut 7/16-32UN
- 5 hex nut MJ12x1 (only with threadneck design 3)

### Terminal design (main terminals)

K screw terminals with metric thread

- 1 K14 (M4, MJ4)

J screw terminals with inch thread

- 1 J14 (8-32UNC-2B)
- 2 J17 (8-32UNC-2B)
- 3 J25 (6-32UNC-2B)

### Characteristic curve

M1 thermal, 1.15-1.38 I<sub>N</sub>

### Terminal screws

- A Phillips screw M4x6
- B Phillips screw 8-32UNC-2Ax6 (MS 51957-41)
- C Phillips screw 6-32UNC-2Ax6 (MS 51957-41)
- D slotted flat head screw M4x6
- E hex screw with Phillips head 8-32UNC-3Ax9.5
- K hex screw with Phillips head 8-32UNC-3Ax7.6
- L Phillips screw MJ4x6
- Z without accessories

### Terminal washers

- 0 without lock washer
- 1 lock washer B4
- 2 lock washer 4.3 (MS 35338-137)
- 3 lock washer B4 and washer 4.4/9.5
- 4 lock washer 3.7 (MS 35338-136)
- 5 lock washer 4.3/9

### Auxiliary contact

- S0 without auxiliary contact
- S1 with auxiliary contact (N/C) (connector to EN 3155-016M2018, size 20)
- S5 with polarized auxiliary contact (N/C)

### Barrier

- T barrier 25.5 mm wide, 37.7 mm long (-S0 only)
- U barrier 19.5 mm wide, 37.7 mm long
- V barrier 25.5 mm wide, 37.7 mm long, colour marking between the terminals (-S0 only)
- X barrier 19.5 mm wide, 34.1 mm long

### Colour of the push button

- (blank) black (standard) (e.g. 7.5)
- A green (e.g. 7.5)
- G green to EN (e.g. 7 1/2)
- N black to EN (e.g. 7 1/2)

### Current ratings

1...25 A

583 - G 4 1 1 - K 1 M1 - A 1 S0 T . - 5 A ordering example

## Ordering information for approved devices

### 583-G411-K1M1-A1S0TN (583-96-TC-K14)

Metric threadneck M12x1 and terminal design -K14 (M4x6), listed by the German Materialamt der Bundeswehr to VG 95345 T11.

### 583-G111-K1M1-A1S1UN

Metric threadneck M12x1 and terminal design -K14 (M4x6) with auxiliary contact -Si, listed by the German Materialamt der Bundeswehr to VG 95345 T11.

### 583-G533-J1M1-B2S0XN (AS 14154)

Threadneck size 7/16-32UNx6.4 and terminal design -J14 (inch thread 8-32), approved to AS 14154.

## Dimensions 583-G411-K1M1-A1S0TN (VG 95345 T11)

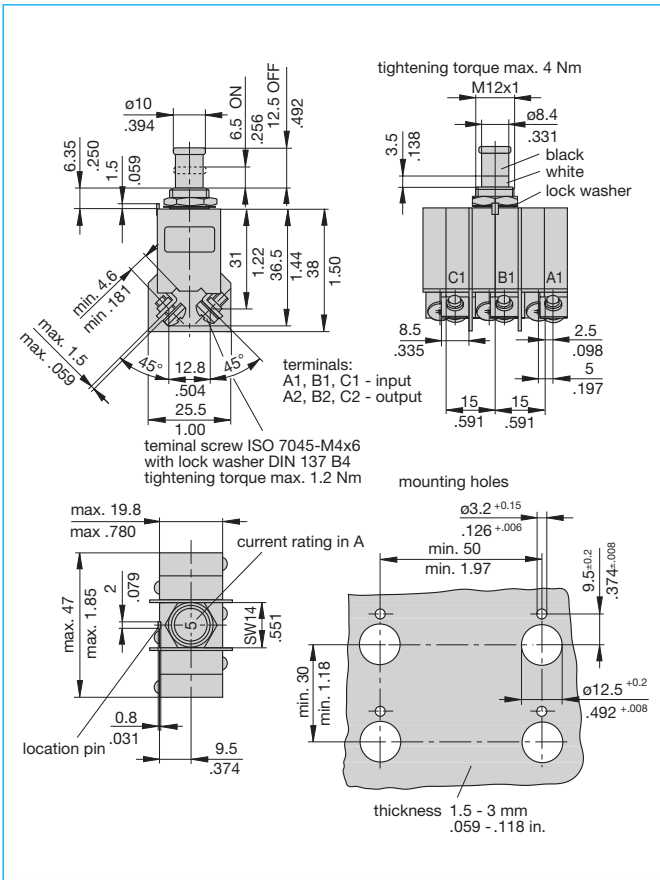

## Dimensions 583-G111-K1M1-A1S1UN (VG 95345 T11)

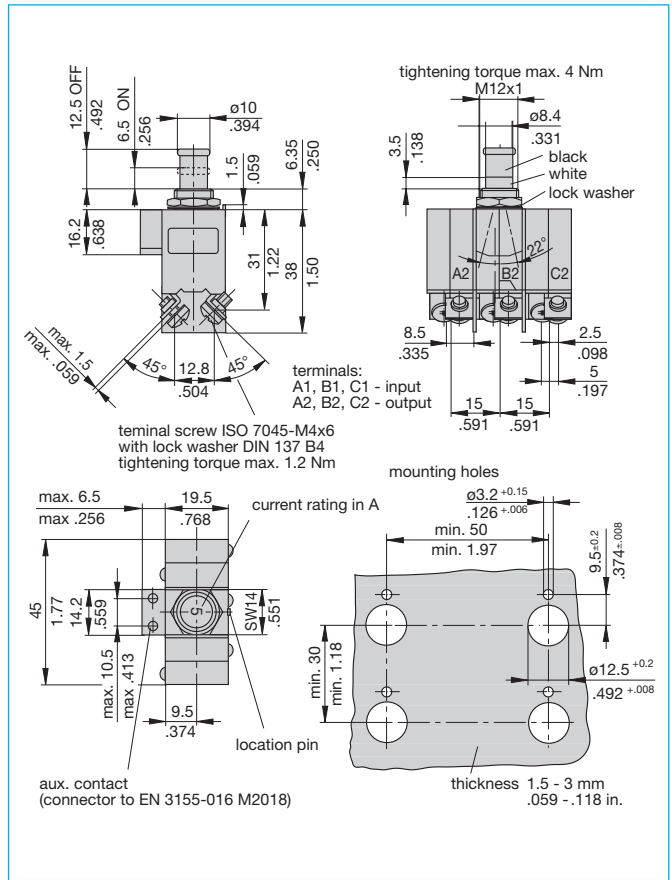

## Dimensions 583-G533-J1M1-B2S0XN (AS14154)

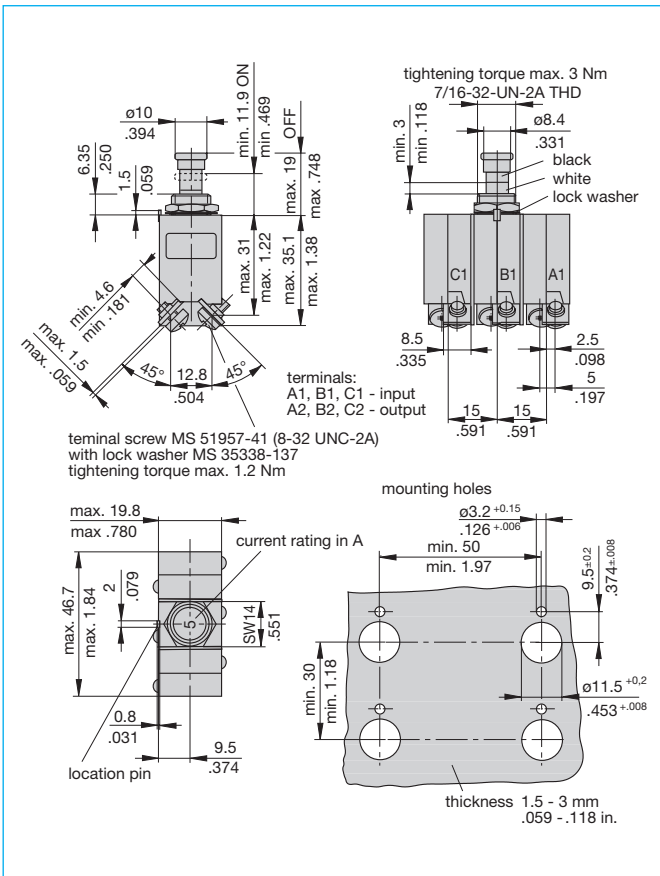

## Other main terminal and threadneck designs

### terminal design -J2

- recommended barrier:
- T or -X for -S0 (without auxiliary contacts)
  - U or -X for -S1 or -S5 (with auxiliary contacts)

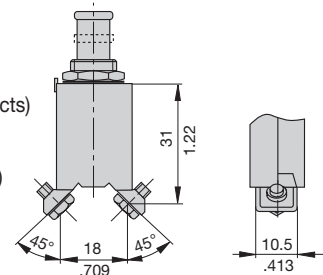

### terminal design -J3

- recommended barrier:
- T for -S0 (without auxiliary contacts)
  - U for -S1 or -S5 (with auxiliary contacts)

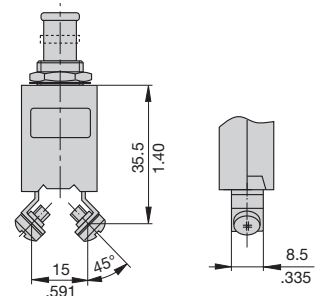

### mounting -G6

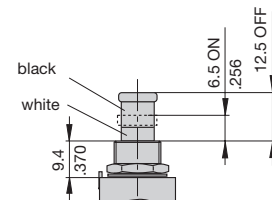

## Internal connection diagrams

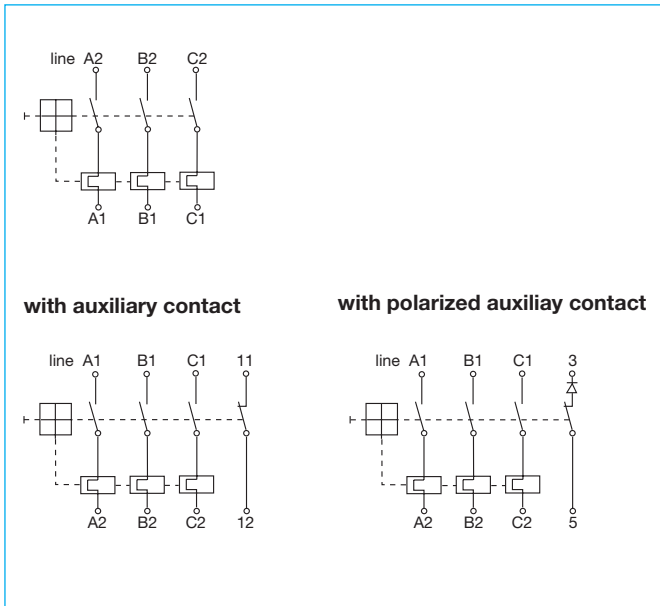

## Typical time/current characteristics

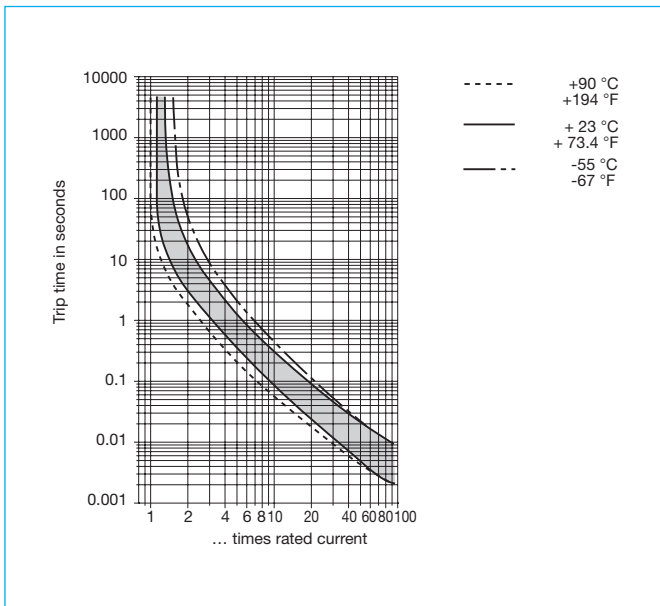

## Accessories

- Splash cover/hex nut assembly with O ring (IP66)**  
 (approved to VG 95345, part 23)  
**X 200 801 08** nickel plated nut, transparent cover  
**X 200 801 03** matt black finish nut, black cover  
**X 200 801 09** matt black finish nut 7/16-32, black cover

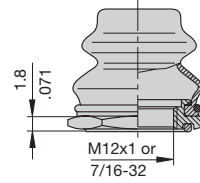

- Splash cover black/hex nut assembly with O ring (IP54)**  
 only for threadneck nut M12 (to VG 95345, sheet 23)  
**X 200 802 01** nickel plated nut  
**X 200 802 02** matt black finish nut

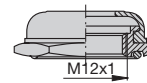

- Actuator extension (black)** to be fitted on the push button  
 (approved to VG 95345, T23)  
**X 200 803 01**

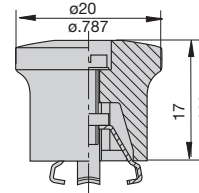

- Identification collar** to be snapped on the push button  
**Y 307 004 01** black  
**Y 307 004 02** white  
**Y 307 004 03** red  
**Y 307 004 04** green  
**Y 307 004 05** blue

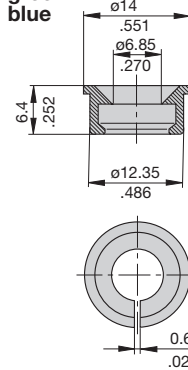

- Lock out ring** to block the push button in OFF position  
**Y 307 005 01** red  
**Y 307 005 02** black

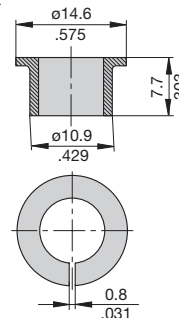

This is a metric design and millimeter dimensions take precedence ( $\frac{\text{mm}}{\text{inch}}$ )

All dimensions without tolerances are for reference only. In the interest of improved design, performance and cost effectiveness the right to make changes in these specifications without notice is reserved. Product markings may not be exactly as the ordering codes. Errors and omissions excepted.